



Increased productivity:

- 360° continuous rotation
- 4-wheel steer
- Standard foam filled tires
- 16 in ground clearance
- 50% gradeability
- Smooth simultaneous proportional controls

Specs at a glance:

- 140° (+70° / - 70°) fly jib
- Up to 21 ft 8 in up and over clearance
- 16 in ground clearance
- 43 second lift speed to full height

507 lb HA 46 JRT 507 lb HA 51 JRT

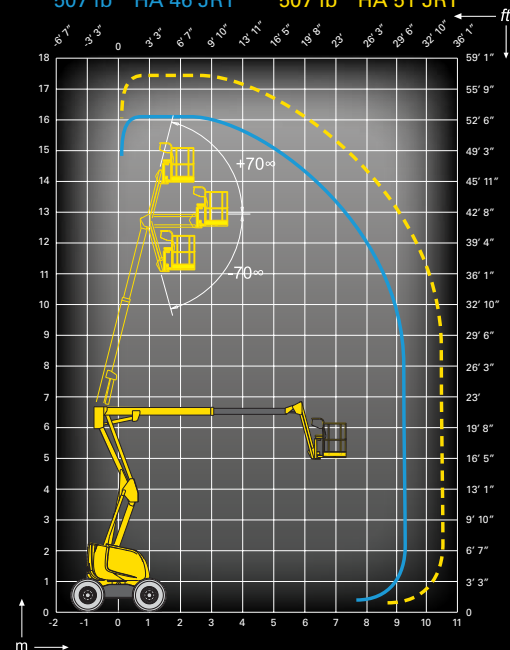

HA 46 / 51 JRT

Rough Terrain Articulating Boom

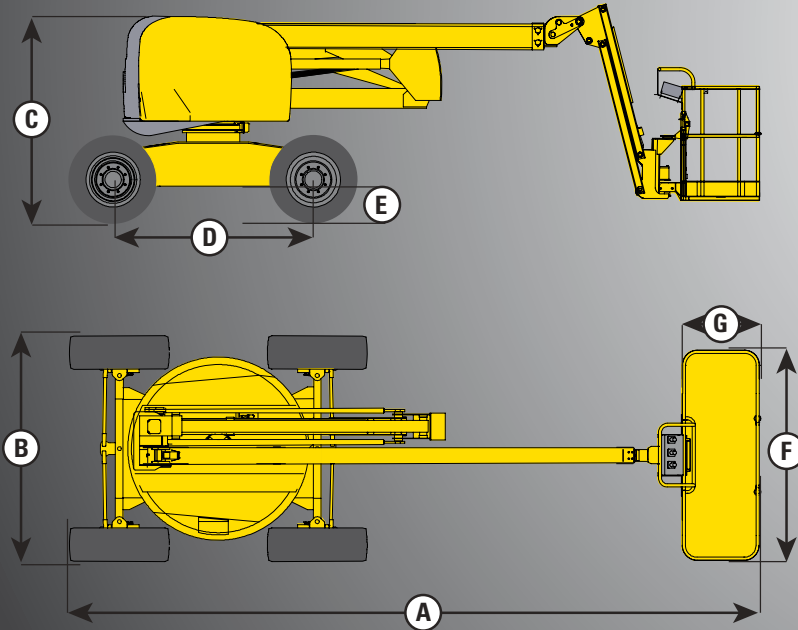

TECHNICAL SPECS

HA 46 JRT

HA 51 JRT

Working height	51 ft 11 in	56 ft 2 in
Platform height	45 ft 11 in	50 ft 2 in
Horizontal outreach	29 ft 10 in	34 ft 9 in
Up and over	21 ft 8 in	
Lift capacity	507 lb	
A - Length	23 ft	25 ft 1 in
B - Width	7 ft 7 in	
C - Stowed height	7 ft 7 in	
D - Wheelbase	6 ft 7 in	
E - Ground clearance	16 in	
F x G - Platform size	5 ft 11 in x 2 ft 7 in	
Transport length	17 ft 5 in	19 ft 4 in
Fly jib range of motion	140° (+70° / -70°)	
Tailswing	0	
Drive speed	0.5 - 3.4 mph	
Outside turning radius	12 ft 4 in	
Inside turning radius	5 ft 9 in	
Turntable rotation	360° continuous	
Hydraulic platform rotation	180°	
Engine	Deutz Diesel 31.2 kW / 42.4 hp	
Gradeability	50%	
Tires (foam filled and wide)	385 / 65 - 22.5	
Hydraulic tank	26 gal	
Fuel tank	19 gal	
Weight	15,435 lb	17,420 lb

STANDARD EQUIPMENT & HIGHLIGHTS

- 4-wheel drive and steer
- Rotating engine tray for easier maintenance
- Fuel tank capacity of 19 gallons
- Safe for use in winds up to 37 mph
- 12 V battery / electrical control system
- Hourmeter
- Swing lock pin
- Towing hooks / lifting eyes
- Zero tailswing
- 43 second lift speed to full height
- Gradeability up to 50%
- Continuous 360° turntable rotation
- Improved working area through articulating fly jib
- Foam filled tires
- 110 V to platform

OPTIONS & ACCESSORIES

- On-board generator
- Large platform
- Travel alarm
- Rotating beacon
- Working light
- Encoded starting device
- Biodegradable hydraulic oil



Haulotte 
GROUP