



Increased productivity:

- ➔ 4-Wheel Drive and 2-front steering wheels
- ➔ Removable operator's control box
- ➔ Foam-filled all-terrain tires
- ➔ Proportional controls

Specs at a glance:

- ➔ 33 ft to 39 ft 3 in working height
- ➔ Max width 6 ft
- ➔ Drive speeds up to 3.4 mph

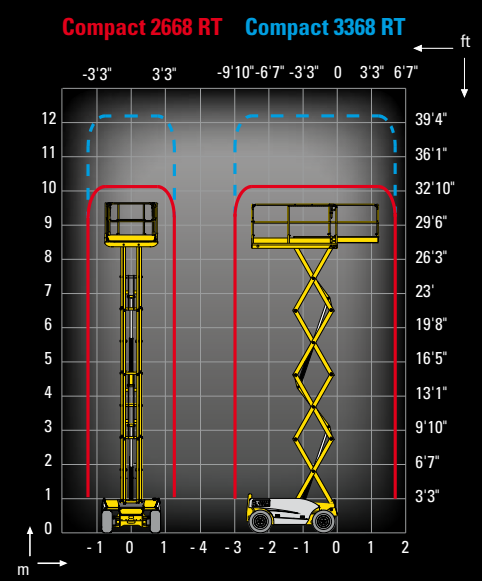

Haulotte **GROUP**

More Than Lifting

www.haulotte-usa.com

COMPACT 2268 RT / COMPACT 3368 RT

Rough-Terrain Scissor Lifts

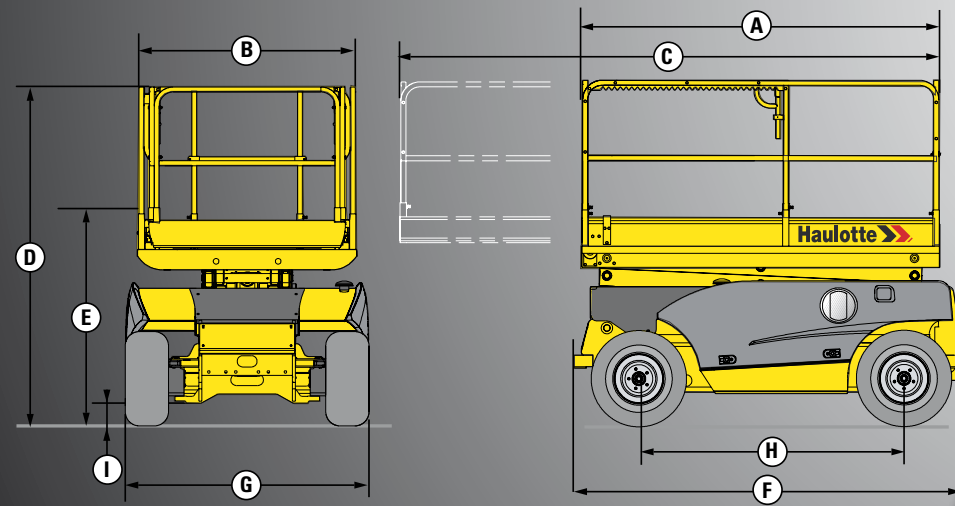

TECHNICAL SPECS

Compact 2668 RT Compact 3368 RT

Working height	33 ft 0 in	39 ft 3 in
Platform height	27 ft 0 in	33 ft 3 in
Lift capacity	1,245 lb	992 lb
A - Platform length - outside	8 ft 2 in	
B - Platform width - outside	5 ft 1 in	
C - Platform length - extended	12 ft 1 in	
Platform extension length	47 in	
D - Stowed height (guardrail)	7 ft 10 in	8 ft 4 in
E - Stowed height (platform)	4 ft 11 in	5 ft 6 in
F - Overall length	8 ft 8 in	
G - Overall width	6 ft 0 in	
H - Wheelbase	6 ft 1 in	
I - Ground clearance	10 in	
Drive speed	0.5 - 3.4 mph	
Gradeability	40 %	
Tilt	3 °	
Lift / lower speed	31 / 27 sec	45 / 39 sec
Turning radius - outside	12 ft 3 in	
Turning radius - inside	4 ft 0 in	
Tires - non-marking	26 x 12 - 16.5	
Hydraulic tank	20 gal	
Fuel tank	8 gal	
Batteries	48 V - 255 Amph (C5)	
Weight	7,300 lb	8,580 lb

STANDARD EQUIPMENT & HIGHLIGHTS

- Extended platform
- Proportional lift and drive
- Removable control box in platform
- Battery charge indicator
- Battery charger with automatic stop
- Lanyard attachment points
- 2-wheel drive
- Free wheeling device
- Tilt controller
- Load managing system in the platform
- Manual platform lowering valve
- Hydraulic brakes
- Towing hooks
- Horn
- Hourmeter

OPTIONS & ACCESSORIES

- Flashing light
- Travel alarm
- Power to platform
- Biodegradable hydraulic oil
- Outriggers (Increase machine weight by 529 lb)



Haulotte 
GROUP