

ELECTRIC SCISSOR LIFTS

OPTIMUM 1530E/1930E



Optimum 1930E

- 30 in width.
- 595 lb platform capacity (Optimum 1530E).
- Go through a standard door.
- Pot Hole protection.



OPTIMUM 1530E/1930E

The Haulotte® advantages

- Compact: stowed height for easy travel through standard doorways
- 6 ft 2 in long and 30 in wide allow operation in the most congested areas
- Outside turning radius 5 ft 6 in ensures excellent manoeuvrability
- 3 in ground clearance allows for both inside and outside use
- Pot Hole protection ensures maximum safety
- High battery capacity
- Robust, reliable and easy to maintain

STANDARD FEATURES

- Non marking tires
- 3 ft platform extension
- Tilt alarm
- 2 drive speed
- 2 wheel drive and steer
- Free wheeling device
- 30 Amp battery charger
- Battery charge indicator
- Hour meter
- Towing hooks / lifting eyes
- Emergency lowering system
- Forklift pockets

OPTIONS & ACCESSORIES

- Travel alarm
- Flashing light
- Work light
- Overload device
- 110 V outlet

Electric scissor lifts

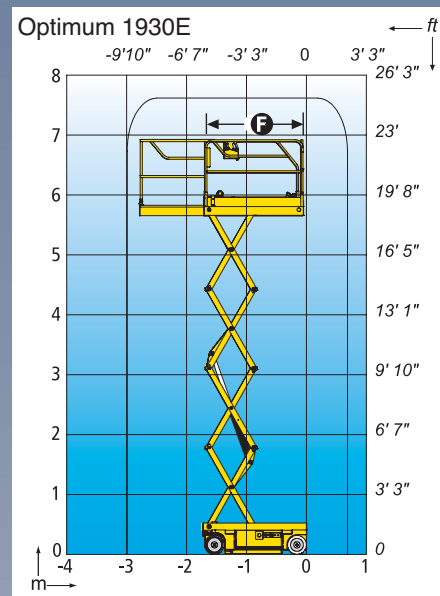
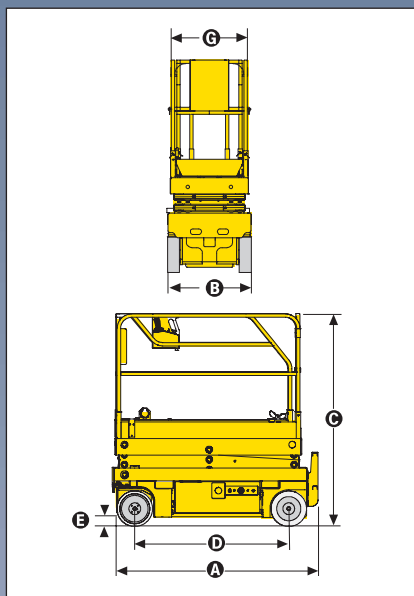

SPECIFICATIONS

	OPTIMUM 1530E	OPTIMUM 1930E
Working height	20 ft 7 in	24 ft 11 in
Platform height	14 ft 7 in	18 ft 11 in
Platform capacity	595 lb	507 lb
A Stowed length	6 ft 2 in	
B Width	30 in	
C Stowed height (guardrails)	6 ft 3 in	6 ft 6 in
Stowed height (platform)	2 ft 7 in	2 ft 10 in
D Wheelbase	4 ft 6 in	
E Ground clearance	3 in	
with deployed Pot Hole	0.5 in	
F x G Platform size	5 ft 8 in x 2 ft 3 in	
Platform extension	3 ft	
Extension capacity	254 lb	
Drive speed	0.4 - 2.8 mph	
Outside turning radius	5 ft 7 in	
Lift / lower (sec.)	20 / 35	23 / 32
Gradeability	25 %	
Controls	Proportional	Proportional
Batteries	24 V / 225 Ah - C20	
Tires (solid / non marking)	12.5 x 4.25	
Hydraulic tank	5.3 gal	
Weight	2,944 lb	3,131 lb

ANSI/SIA A92.5 and CSA/B354-2 Standards Compliance



HAULOTTE US INC • 1530 Tilco Drive - Suite B • Frederick, MD 21704 - USA
Toll free : +1 877-HAULOTTE • E.mail : sales@us.haulotte.com • www.haulotte.us

HAULOTTE US INC • 1925 Shiloh Road • Building 3, Suite 400 • Kennesaw, GA 30144 - USA • Phone : 770-795-1111 • Fax : 770-795-1118

Haulotte 
GROUP