



**Increased productivity:**

- ➔ Compact - stowed height for easy travel through standard doorways
- ➔ Outside turning radius of 5 ft 7 in
- ➔ 3 ft platform extension
- ➔ 3 in ground clearance
- ➔ Rugged steel construction
- ➔ Easy to maintain

**Specs at a glance:**

- ➔ 24 ft 11 in working height
- ➔ 30 in wide
- ➔ 2.8 mph max drive speed
- ➔ Inside turning radius 0 in

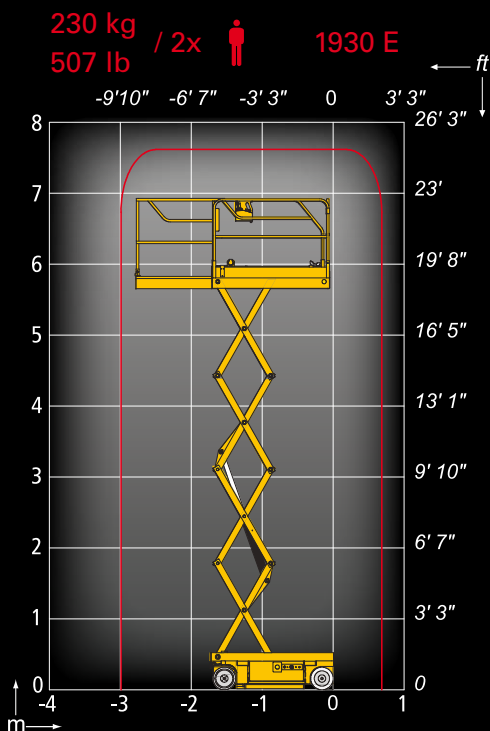

**Haulotte**   
GROUP

More Than Lifting



# OPTIMUM 1930 E

Electric Scissors

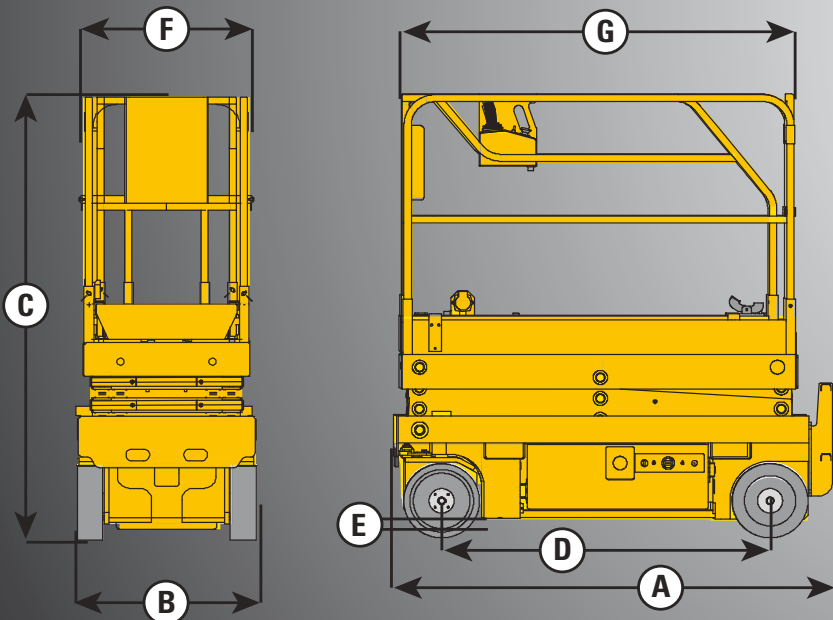

## TECHNICAL SPECS

## OPTIMUM 1930 E

Working height	24 ft 11 in
Platform height - raised	18 ft 11 in
Platform height - lowered	2 ft 11 in
Lift capacity	507 lb
Capacity on platform extension	250 lb
A - Length	6 ft 2 in
B - Width	2 ft 6 in
C - Stowed height	6 ft 6 in
D - Wheelbase	4 ft 6 in
E - Ground clearance	3 in
F x G - Platform size	2 ft 6 in x 5 ft 8 in
Platform extension	3 ft
Drive system	Hydraulic - dual front
Drive speed	0.4 - 2.8 mph
Lift / lower time	23 / 32 sec
Outside turning radius	5 ft 7 in
Inside turning radius	0 in
Lift / Lower time	23 / 32 sec
Batteries	4 x 6 V, 220 amp-hr
Gradeability	25%
Tires	12.5 in x 4.25 in
Brakes	Dual multi disc
Weight	3,131 lb

\*15 ft model available. For more information contact factory and request information on the Optimum 1530 E.

## STANDARD EQUIPMENT & HIGHLIGHTS

- Self-diagnosing system
- Removable rails
- Forklift pockets
- 110 V to platform
- Female charger plug at base
- Horn
- Lanyard anchors
- Battery charge indicator
- Removable upper controls
- Built-in 30 amp 110 V / 60 hz battery charger
- Drivable at full platform extension
- Hydraulic pot hole protection
- Travels through a standard doorway
- Slide-out batteries
- Non-marking tires

## OPTIONS & ACCESSORIES

- Alarm package
- Motion flashing beacon
- 70-watt platform light
- Flashing light with on / off switch
- Overload device
- Air to platform
- Extension cable for upper controls
- 800-watt power inverter
- Wire spool holder
- Pipe rack
- Centralized battery filling option



**Haulotte**   
GROUP